

Fashion Bed Group

A Division of Leggett & Platt Incorporated

Part List For Belmont HB

PARTS IN TWIN HEADBOARD BOX:

- (A) HEADBOARD POSTS-2
- (B) HEADBOARD GRILL-1
- PART #334801 HARDWARE FOR HB**
- (C) 1/4-20 X 54mm CONNECTING BOLT-4
- (D) ALUMINUM EXTRUDED SELF-LOCKING HOUSING-4
- (E) 1/4-20 2 3/4" STOVE HEAD BOLT-4
- (F) 1/4-20 LOCK NUT W/WASHER-4
- (G) 40mm X 10mm WOOD DOWEL-4
- (H) OPEN WRENCH

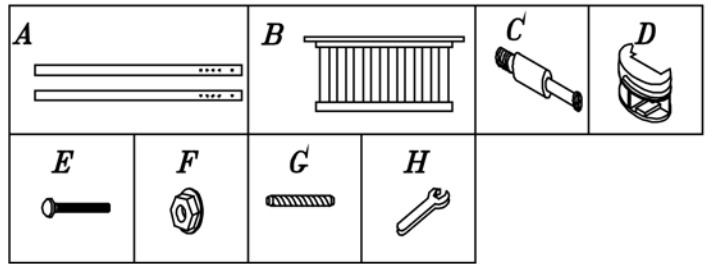

PARTS IN FULL & QUEEN HEADBOARD BOX:

- (A) HEADBOARD POSTS-2
- (B) HEADBOARD GRILL-1
- PART #334802 HARDWARE FOR HB**
- (C) 1/4-20 X 54mm CONNECTING BOLT-4
- (D) ALUMINUM EXTRUDED SELF-LOCKING HOUSING-4
- (E) 1/4-20 2 3/4" STOVE HEAD BOLT-4
- (F) 1/4-20 LOCK NUT W/WASHER-4
- (G) 40mm X 10mm WOOD DOWEL-4
- (H) OPEN WRENCH
- (I) 1/4-20 2" STOVE HEAD BOLT-4

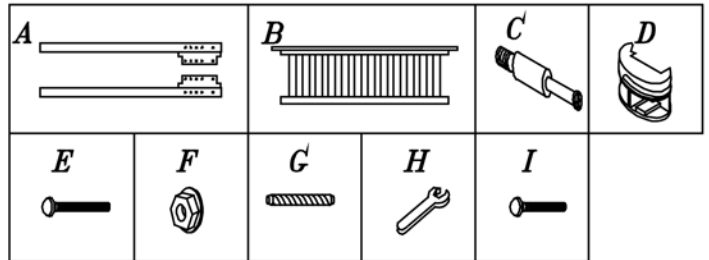

SAVE ALL PACKAGING MATERIALS UNTIL PRODUCT IS FULLY ASSEMBLED. HARDWARE AND SMALL PIECES MAY NOT BE SEEN AND BE ACCIDENTALLY DISCARDED WITH PACKAGING MATERIALS.

Step 1

Instruction Sheet

- Insert steel pins (C) into posts (A). (See Fig. 1) Do not over tighten.
- Insert wood dowels (G) into posts (A). (See Fig. 1)

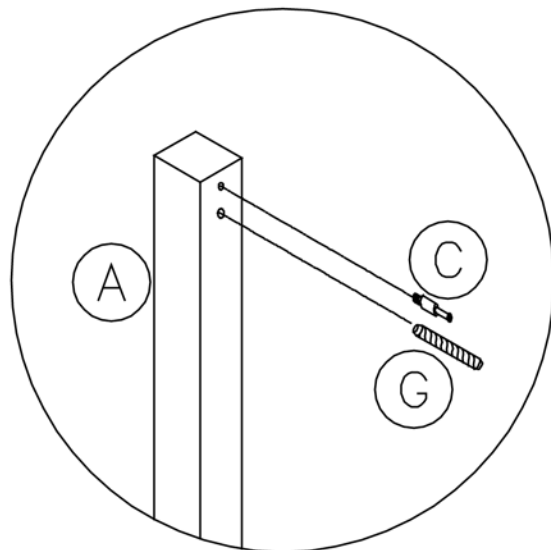
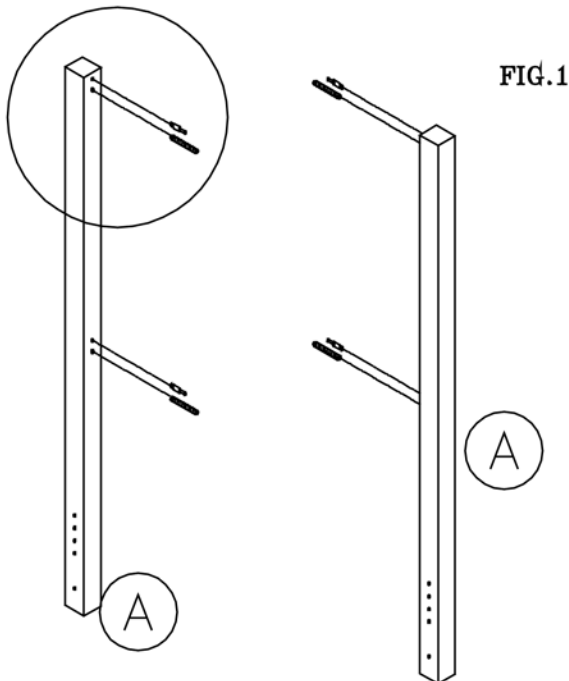

Step 2

Instruction Sheet

- Insert locking housing (D) into the back side of the top and bottom rails of the grill panel (B). Make sure the arrow in the locking housing is pointing towards the steel pin (C) in post (A). (See Fig. 1 & 2)
- Now align the holes on the ends of the rail in grill (B) with the steel pins (C) and wood dowels (G).
- Secure the post to the grill panel by turning the aluminum self locking housing clockwise (D). (See Fig. 2)

FIG. 2

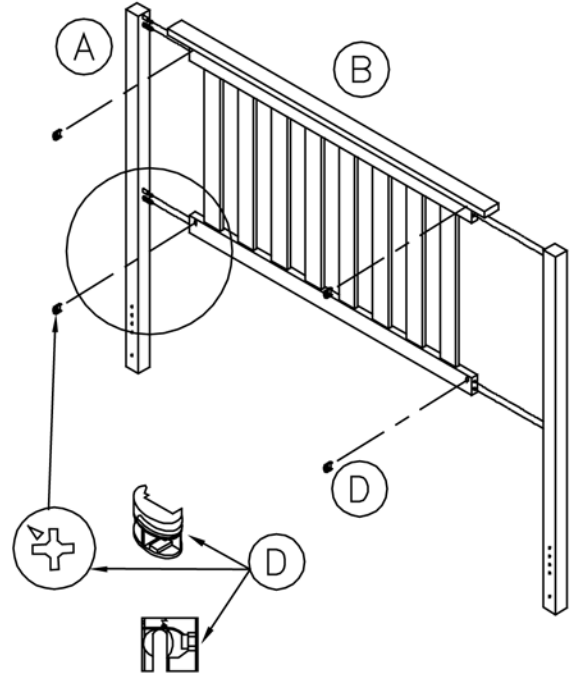
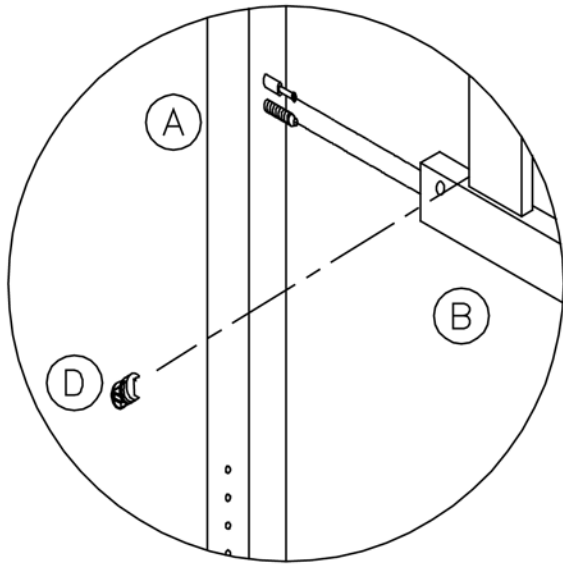

Step 3

- Insert screw (E) through post (A).
- Align screws in headboard panel post to holes in frame bracket. Secure screw with nut (F). (See Fig. 5)
- REPEAT ON OTHER HEADBOARD POST
- USE WRENCH (H) TO TIGHTEN ALL SCREWS SECURELY.
- NOTE: FOR FULL SIZE ASSEMBLY USE SCREWS (I) THAT ARE INCLUDED IN THE HARDWARE

FIG. 5

